

# Meet your phone

**verizon**<sup>✓</sup>

One Talk<sup>SM</sup> EXP40 Expansion Module

[www.verizonwireless.com/One-Talk](http://www.verizonwireless.com/One-Talk)

## Packaging Contents

The following items are included in your package. If you find anything missing, contact your system administrator.

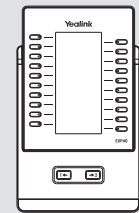

Expansion Module

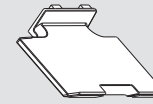

Stand

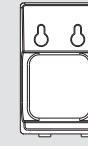

Wallmount Bracket (Optional)

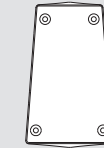

Connecting Sheet

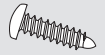

Screw



Connecting Cord

## Assembling the EXP40

Attach the stand or the optional wall mount bracket, as shown below:

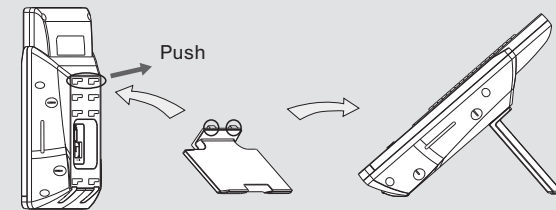

Desk Mount Method

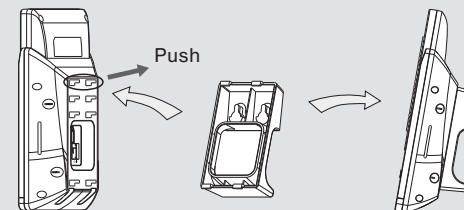

Wall Mount Method (Optional)

Note: Optional Wall Mount can be purchased separately.

## Connecting to the Phone

1. Connect the EXP40 and the phone using the supplied screws and connecting sheet, as shown below:

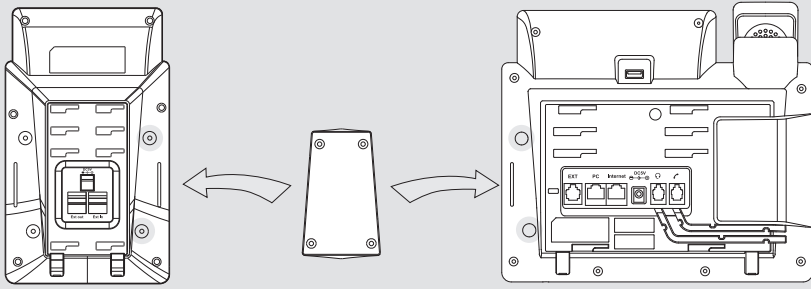

Your phone and the expansion module will be connected as shown below:

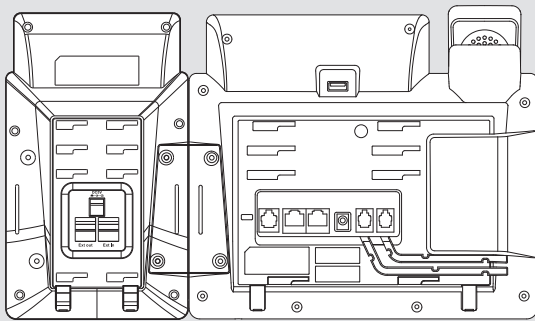

## Connecting to two Modules

2. Follow the same step to connect two expansion modules:

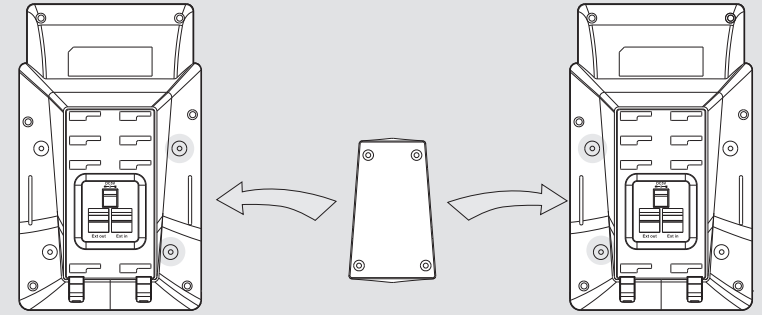

Your phone and the two expansion modules will be connected as shown below:

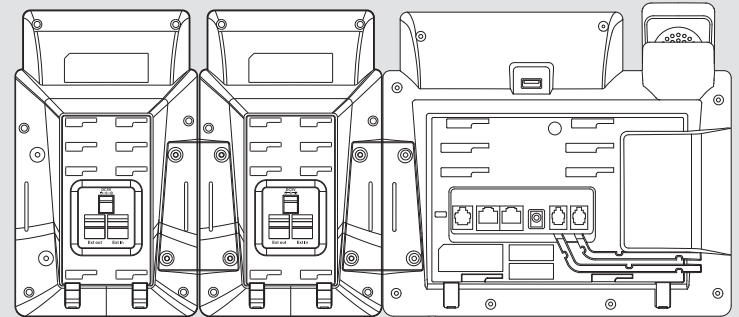

Note: The T46G IP phone can support six expansion modules at most. But if you use more than two expansion modules, you need to connect an additional power adapter to any one of the expansion modules.

## Connecting the Cords

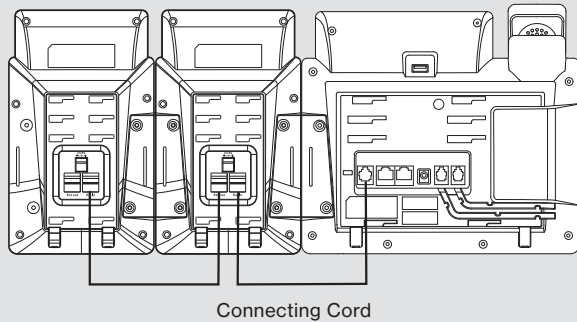

3. Connect the Ext jack of the IP phone and the Ext in jack of the first module using a connecting cord. If you want to connect another module, connect the Ext out jack of the first module and the Ext in jack of the second module using a connecting cord.



Note: You can connect six modules at most. You just need to connect the Ext in jack of the previous module and the Ext out jack of the next module using a connecting cord.

Then you can attach the stand, the power adapter and the Ethernet cable to the phone, connect the handset and headset to use.

## Basic Configurations

The EXP40 supports 40 DSS soft keys in two screen pages. Each page displays 20 DSS soft keys. You can press  or  to switch between the two pages and use your desired DSS soft keys.

You can assign a speed dial number. Press the desired DSS key of EXP40 for about 5 seconds. The phone LCD screen will prompt the setting of this key. The following sections provide you with detailed instruction for assigning some frequently used features to the DSS keys via web user interface.

## Placing a call

### Using the handset

Pick up the handset, press the soft key corresponding to the number you wish to call.

### Using the speakerphone

With handset on hook, press the soft key corresponding to the number you wish to call.

### Using the headset

With the headset connected, press the soft key corresponding to the number you wish to call.

### Call transfer

Press or the Transfer soft key during an active call. This will place the call on hold. Press the soft key corresponding to the number you wish call.

## Set up Speed Dial

When the Phone is idle,

- Press and hold an unused line key until Line Key screen detail displays on the T46G LCD screen
- Press < and > arrow to select the Type as Speed Dial  
Select Line 1 as Account ID  
Enter the name as **Label**  
Enter the number as **Value**
- Click **Save**.

You can now use this line key to initiate the preset speed dial.

